

TOLERANCIAS NO ESPECIFICADAS

ARISTAS	LONGITUDES EN mm	
CHAFLANES = 0,5x45°	DE 0 A 6 = ± 0,1	DE 120 A 400 = ± 2
RADIOS = 0,5	DE 6 A 30 = ± 1	DE 400 A 1000 = ± 2,5
ÁNGULOS = ±1°	DE 30 A 120 = ± 1,5	MÁS DE 1000 = ± 3

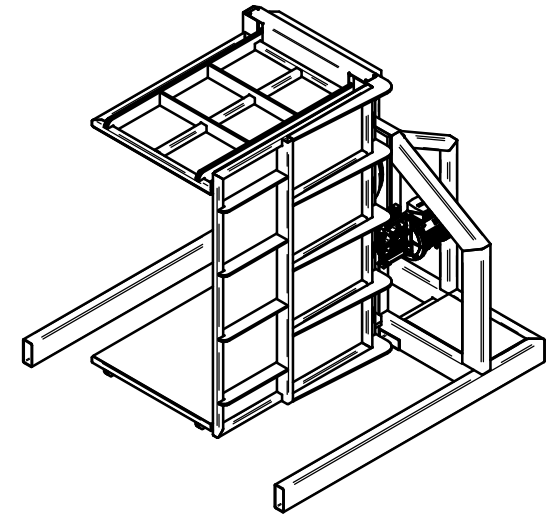
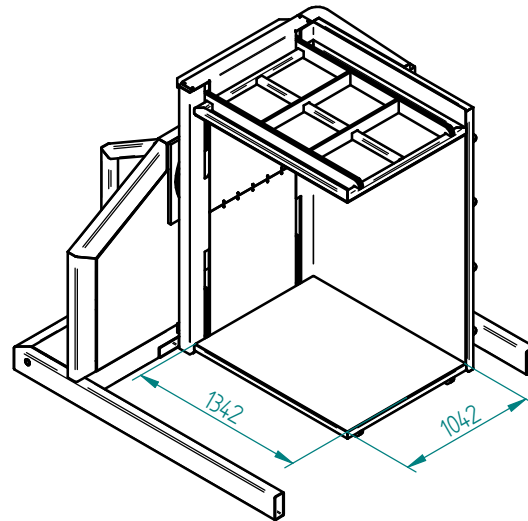
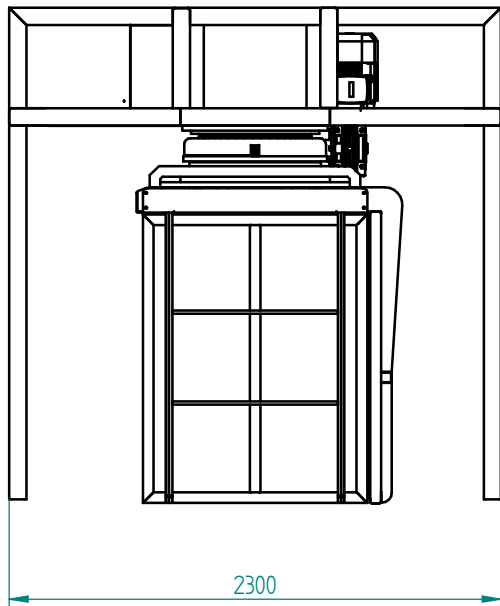
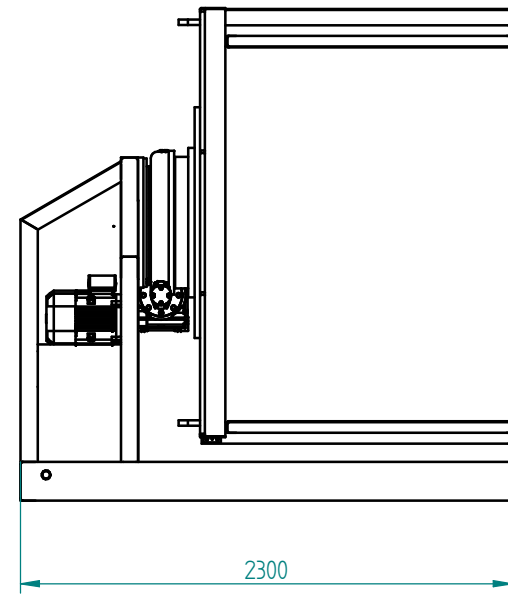
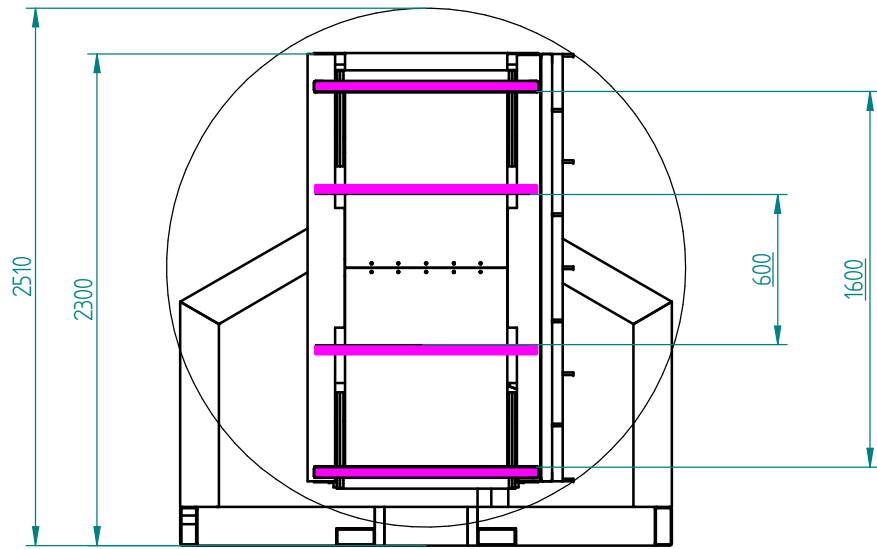

0	22-02-2021	VOLTEADOR	Javier	R.Of.Técnica	R. Producción	R. Calidad
Rev.	Fecha	Descripción	Elaborado	Revisado	Verificado	Validado
REF 10074		Nº PLANO:			CLIENTE	Escala: 15
				Código: FO. 73.01		1 de 2

TOLERANCIAS NO ESPECIFICADAS

ARISTAS	LONGITUDES EN mm	
CHAFLANES = 0,5x45°	DE 0 A 6 = ± 0,1	DE 120 A 400 = ± 2
RADIOS = 0,5	DE 6 A 30 = ± 1	DE 400 A 1000 = ± 2,5
ÁNGULOS = ±1°	DE 30 A 120 = ± 1,5	MÁS DE 1000 = ± 3

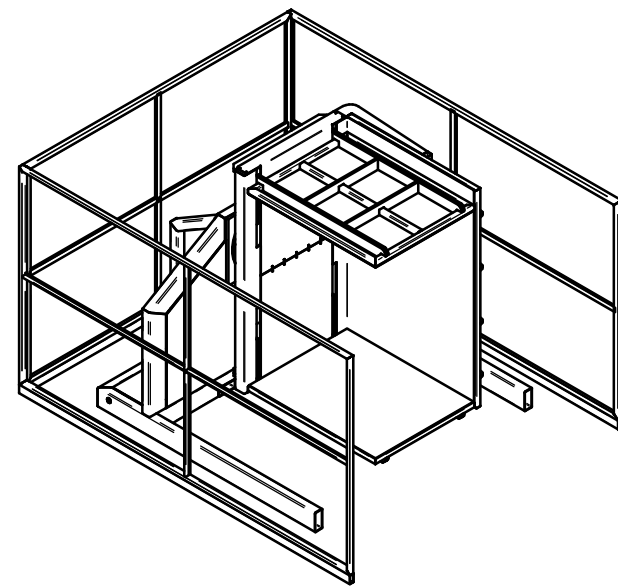
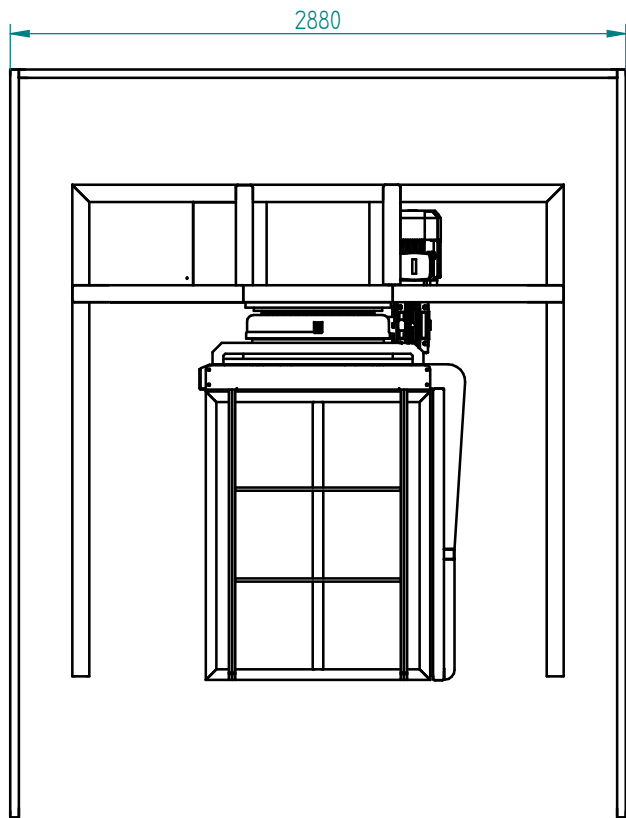
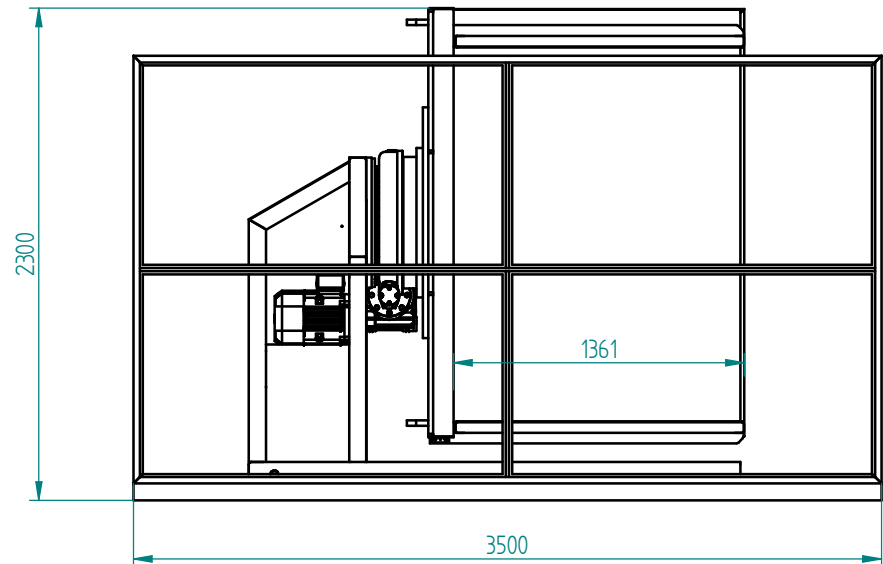
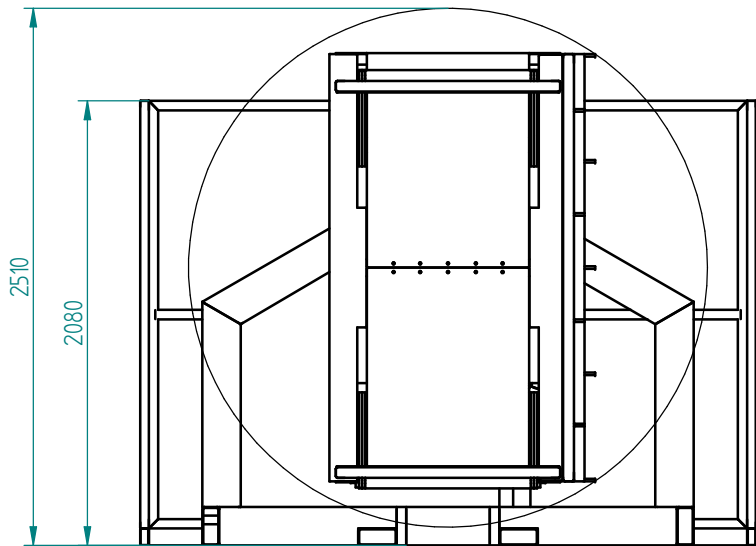

0	22-02-2021	Conjunto	Javier	R.Of.Técnica	R. Producción	R. Calidad
Rev.	Fecha	Descripción	Elaborado	Revisado	Verificado	Validado
REF 10074		Nº PLANO:	CLIENTE			Escala: 15
			Código: FO. 73.01			2 de 2